

# Intelligent Parking and Toll System Using IoT “IParkAT”

Gayathri G<sup>1</sup>, M Swathi<sup>2</sup>, Monisha D<sup>3</sup>, Monisha Jayaker<sup>4</sup> and K Ezhilarasan<sup>5</sup>

1-2 Department of Electronics and Communication, Sambhram Institute of Technology, Bengaluru, Karnataka, India  
Email: gayathriguru1995@gmail.com, swathim30@gmail.com, monishashetty4@gmail.com,  
monisha.jay19@gmail.com, murali981983@gmail.com

**Abstract**— Rising traffic congestion is an unavoidable condition in growing metropolitan areas across the world. Since, the majority of people use personal vehicle to commute, finding a parking space is a tedious task. Currently, the parking and toll system is semi-automated everywhere. This paper introduces a solution to cope with the mobility problem by using “Smart cards” incorporated with IoT to completely eliminate human intervention and alleviate traffic congestion. To facilitate this, a user-friendly website is proposed that displays 3 webpages i.e., to book a parking slot, to recharge the “Smart cards” and to view the Toll transactions. The hardware portion of this prototype consists of a system with sensor networks that communicate with the website to update the database.

**Index Terms**— Internet of Things (IoT), Smart cards, web-site, modules, sensor-networks.

## I. INTRODUCTION

In the present-day scenario, traffic in metropolitan cities is the main concern. According to the World Health Organization, road traffic injuries caused an estimated 1.25 million deaths worldwide in the year 2010 [4]. Two major reasons are the parking space issue and the slow-moving traffic in highways. A recent survey [5] suggests that during the peak hours, 40% of the traffic is generated by searching for parking spaces. Inefficient use of the existing parking space, people circle the block cruising for parking leads to wastage of time and fuel. Furthermore, long queues of vehicles at the toll plaza for the cash transaction causes clogged traffic. To diminish the traffic congestion and human interference, an intelligent parking and toll system have been deployed. The toll management system was designed to resolve the problem of the different charging unit on the highway where the charging units set their own closed facilities for charging the traveller independently at every toll plaza.

The concept of Internet of Things provides an ecosystem of connected physical objects that are accessible through the internet. The embedded technology in the objects helps them to interact with the internal states or the external. This prototype uses RFID technology as RFID cards cannot be cloned and therefore it minimizes the theft of vehicles. One of the advantages of this system is, a single RFID card can be used for parking as well as in the toll system. It is incorporated with the IoT.

The system proposed is implemented using a web application. The parking system has sensor networks that interact with the web application and updates the database. In the toll system, the RFID cards can be recharged using the web978 portal, thus providing cashless transactions in the toll booths. This paper is organized as follows: Section II discusses the related work of our prototype. Section III describes the

proposed architecture. Section IV presents the implementation of the system. Section V presents the two modules, being parking system and toll system and how IoT is enabled. Section VI is conclusion of our work

## II. RELATED WORK

Many parking guidance systems have been developed in the past years. In this section, several existing parking guidance approaches and their limitations are studied. In some studies [1, 3], the authors proposed an algorithm for treating the real-time parking. First, they used an algorithm to schedule the online problem of a parking system into an offline problem, then set up mathematical model describing the offline problem as a linear problem and finally designed an algorithm to solve this linear problem. Finally, they evaluated the proposed algorithm using experimental simulations of the system.

Bonde *et al.* [7] aimed to automate the car and the car parking. The paper discusses a project as a prototype of an automated car parking system that can regulate the number of cars that can be parked in a given area at any given time based on the availability of parking spaces using an Android based application. The difference between the *Bonde* system and the other existing systems is that the authors were aiming to make the system as a little human dependent as possible, on the other hand, most existing systems require human intervention to park the car.

Further, the existing applications do not provide any provision to check the status of the parking slots available. Also, there is no existing system that provides a “single card” to manage both toll and parking system and fully automate the existing parking and toll system under one roof of web application and “card”.

## III. PROPOSED ARCHITECTURE

### A. System overview

The prototype was derived from the idea of IoT. It was developed to make the existing parking and toll system better, user- friendly and fully automated. The proposed architecture consists of a TIVA C series board which acts as a client in our application. IoT technology enables the client to communicate with the server through a common protocol in a secured manner. Two different modules are present in this system to perform the on-road activity.

The first module being “parking system” and the second being “toll system”. Here, a website has been developed where every user can pre-book the parking slot by looking into the slot availability in each area, recharge the smart card and view the transaction activities.

The main highlight of the system being the universal visibility of the available parking slots that could be viewed on the website. This indicates that the website is dynamic and hence the user gets unerring information about the parking slots. The user is initially required to login to the website after which the parking slot can be booked in the desired area. Once the online booking is done, these details are updated to the database.

Further, the user is notified with a message for every recharge of the “Smart Card”. Hence, at the entry of parking system, the user is validated and guided to the booked slot. In the exit of the parking system, the amount of parking is deducted which is updated to the database and can be dynamically viewed on the website. Then at every toll plaza, as the user passes the toll booth, the respective amount is deducted from the “Smart Card” which can again be viewed on the website.

## IV. IMPLEMENTATION

Elements in the system are:

- **Server:** This entity stores all the resource information provided by various peripherals of the toll and parking system. It allows the user to take the appropriate action regarding booking of slot and recharge of the card.
- **Processing Unit:** EK-TM4C123GXL is used along with CC-3100 Wi-Fi module. This is interfaced with sensors and other peripherals to collect the data required. The data is pushed to the database and is updated on the website.
- **Peripherals:** IR sensors, RFID reader, Servo motor and LCD display are the peripherals used. IR sensor present at every slot detects the presence of the vehicle. These IR Sensors are monitored every 10sec.

RFID Reader is used for validating the “Smart Card”. The Servo motor acts as the barrier at the entrance, exit and toll booth.

- Listener: This acts as an interface between the hardware system and server. Data from the client/server is pushed into the server/client and waits for the response.
- Website: A user- friendly .Net platform to interact with the system. It contains various webpages i.e., to book the parking slot in the desired area, to recharge the smart card and to look for the transactions. Universal availability of parking slots is displayed on the website

## V. METHODOLOGY

The block diagram of the prototype is shown in figure 1. The working model of the parking and toll system is depicted in figure 8 and 9.

### A. Parking System

The user is first required to login to the website using the credentials. Every user has a RFID tag that consists of a 10-digit code (Smart card). The unique feature of the smart card is that it cannot be cloned. RFID tag has an electronically stored identification number that can be easily retrieved. The user can book the slots in the desired area using the RFID number. This data is updated to the database. At the entrance of the parking system as shown in figure 2, there exists a network connected RFID reader that sends power as well as commands to the RFID tag. The user is required to flash the RFID tag and the data is read. If the tag is validated and has enough balance, the gate opens and the person is directed towards the slot. IR sensors. present at each slot sends the data continuously to the server every 10 seconds. The server sends an ideal condition which is checked for validity at the entrance. Once, the vehicle is parked, the IR sensor detects the presence of an object and simultaneously updates the webpage. This ensures that the slot is blocked. Further, at the exit of parking system as discussed in Figure 3, the user is required to flash the RFID tag where the respective parking related amount is deducted and updated in a webpage.

### B. Toll System

Due to the frequent halts at every toll booth in the highway, there exists slow moving traffic. To eliminate this, at every toll booth, RFID reader is installed. As the traveller passes through the toll booth and RFID tag is flashed, the amount from the RFID tag is deducted which is depicted in Figure 4. Depending upon the highway/area, different charging units are deployed.

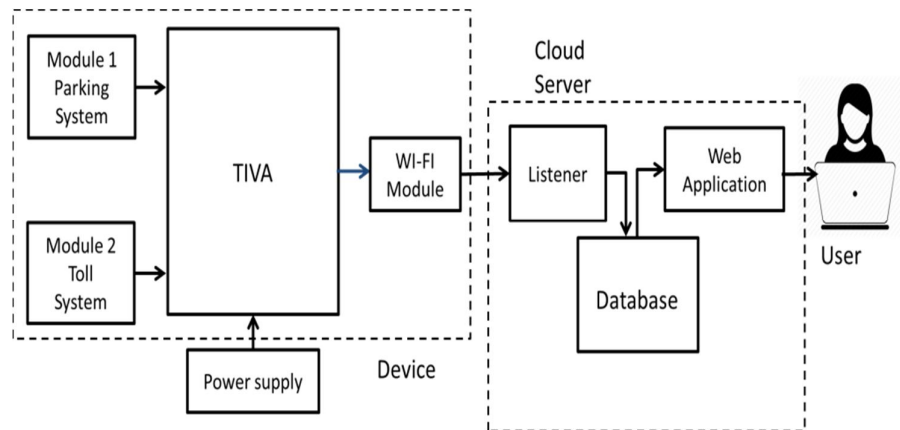

Figure 1. The Prototype Of The System.

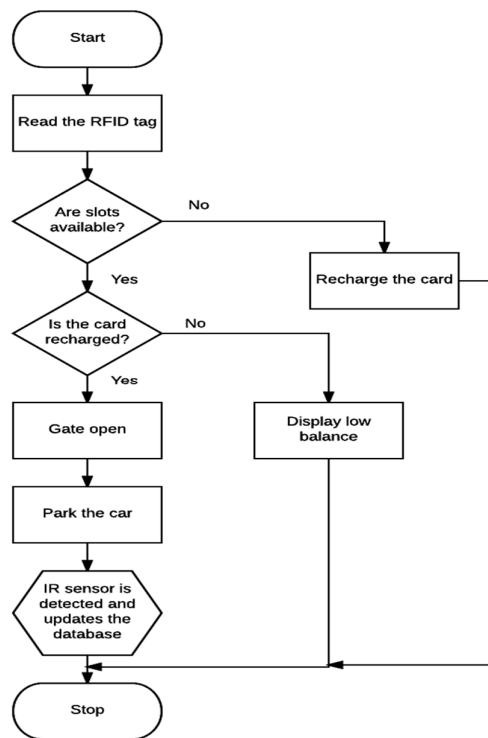

Figure 2. Entry system of parking space

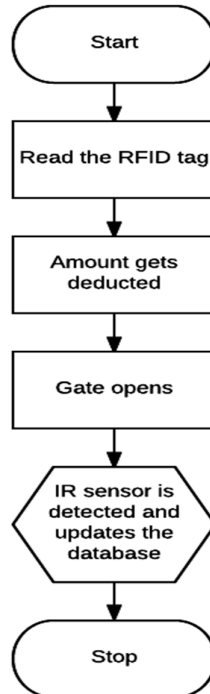

Figure 3. Exit System Of The Parking Space

### C. Device Identifier

Communication between the device and server can be achieved by transmission of several data formats.

TABLE 1. PACKET FORMAT FOR PARKING AND TOLL SYSTEM

R	^	Device number	^	10-digit RFID number
---	---	---------------	---	----------------------

where device number 1- Indicates toll system.  
 2- Indicates parking entry system.  
 5- Indicates parking exit system.  
 depending upon the area code in the database.

TABLE 2. PACKET FORMAT FOR IR SENSOR VALUES

2	^	IR sensor 1	^	IR sensor 2	^	IR sensor 3	^	IR sensor 4
---	---	-------------	---	-------------	---	-------------	---	-------------

where 2 indicates the area code that is stored in the database. The digital value '1' or '0' takes the place of IR sensor indicating if the vehicle is present in the slot or not respectively.

The web application consists of 3 webpages:

- 1) Toll Dashboard: Here, the toll transactions of a user can be viewed as depicted in Figure 5.
- 2) Parking Dashboard: As shown in Figure 6, the user can book the parking slots for the desired area using this webpage. '0' indicates that the slots are vacant. '1' indicates the slot is blocked by an obstacle and '2' ensures that the slot is booked.

Recharge Dashboard: Amount can be recharged to the RFID tag and the user is intimated with a message. This is indicated in Figure 7.

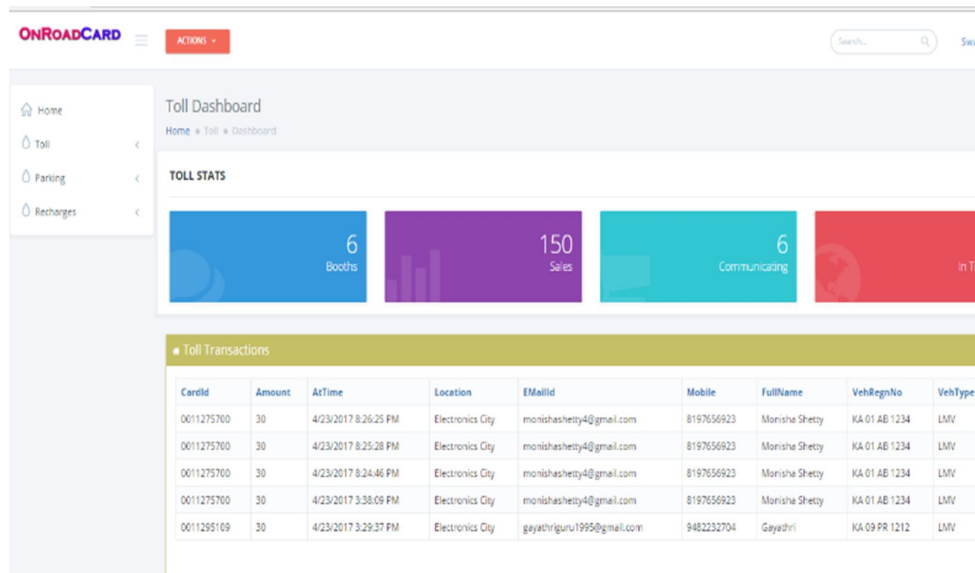

Figure 5. The Toll Dashboard

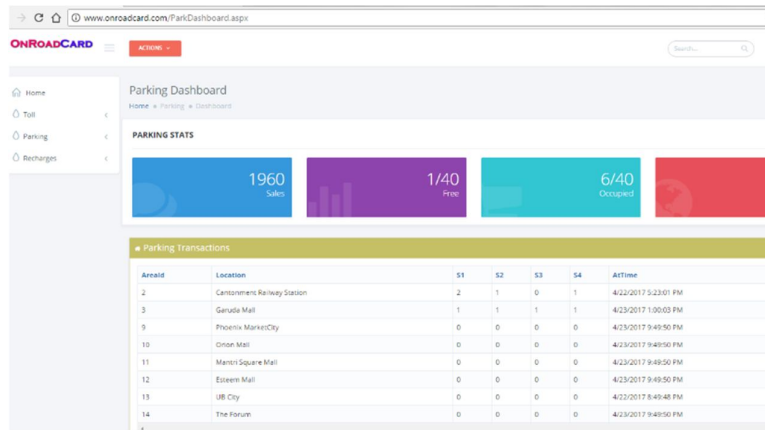

Figure 6. Parking Dashboard

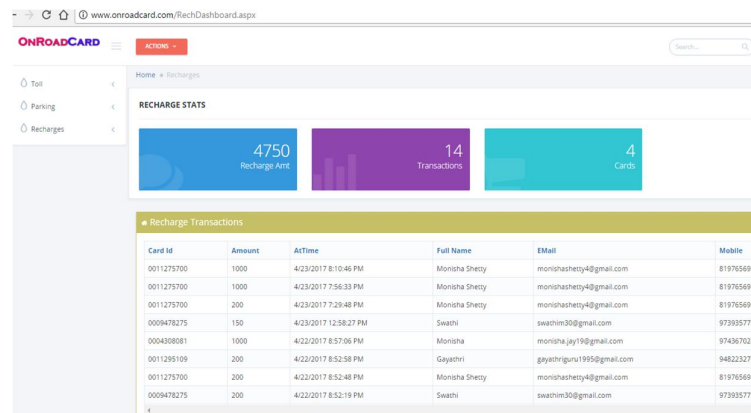

Figure 7. Recharge Dashboard

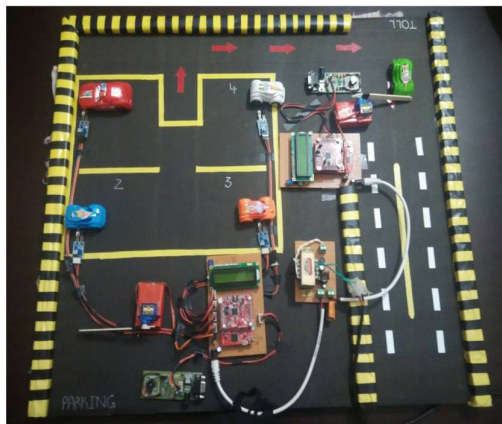

Figure 8. Working Model Of The Prototype- I



Figure 9: Working Model Of The Prototype-2

## VI. CONCLUSION

The main intention of this prototype is to develop a parking and toll system using Internet of Things. Since IoT is the trending area on the Internet to access information remotely and the world is moving towards digitalization, our prototype provides a provision to book the parking slot online, recharge the "Smart Card" and view the toll transactions promoting the cashless transaction and highlighting the universal visibility of parking slots on the webpage. At the entrance of each of the system, RFID reader is present which validates the "Smart Card".

Further, the IR Sensors present at every slot is monitored every 10sec to detect the presence of a vehicle and update the webpage regarding the availability of the slot. These features collectively alleviate traffic congestion, reduce fuel consumption and provide a user-friendly interface to access parking and toll facility under one roof.

## REFERENCE

- [1] World Health Organization, "Road traffic injuries"[Online], Available: <http://www.who.int/mediacentre/factsheets/fs358/en/>
- [2] Parking Today[Online], Available: <http://www.parkingtoday.com/blog/2013/09/30-of-city-traffic-is-looking-for-parking-how-do-you-know-sfpark/>
- [3] Y. Geng and C. G. Cassandras, "A new 'smart parking' system based on optimal resource allocation and reservations," in *Proc. 14th Int. IEEE Conf. Intell. Transp. Syst. (ITSC)*, Oct. 2011, pp. 979\_984.
- [4] X. Zhao, K. Zhao, and F. Hai, "An algorithm of parking planning for smart parking system," in *Proc. 11th World Congr. Intell. Control Autom. (WCICA)*, 2014, pp. 4965\_4969.
- [5] D. J. Bonde, R. S. Shende, K. S. Gaikwad, A. S. Kedari, and A. U. Bhokre, "Automated car parking system commanded by Android application," in *Proc. Int. Conf. Comput. Commun. Inform. (ICCCI)*, Coimbatore, India, Jan. 2014, pp. 1\_4.
- [6] Y. Geng and C. G. Cassandras, "New 'smart parking' system based on resource allocation and reservations," *IEEE Trans. Intell. Transp. Syst.*, vol. 14, no. 3, pp. 1129\_1139, Sep. 2013.
- [7] L. Mainetti, L. Palano, L. Patrono, M. L. Stefanizzi, and R. Vergallo, "Integration of RFID and WSN technologies in a smart parking system," in *Proc. 22nd Int. Conf. Softw., Telecommun. Comput. Netw. (SofCOM)*, 2014, pp. 104\_110.
- [8] The TI website.[Online] Available: [https://www.cse.iitb.ac.in/~erts/html\\_pages/Resources/Tiva/TM4C123G\\_LaunchPad\\_Workshop\\_Workbook.pdf](https://www.cse.iitb.ac.in/~erts/html_pages/Resources/Tiva/TM4C123G_LaunchPad_Workshop_Workbook.pdf)